



Ref :MMHC14SR\_GB

Emetteur :MF

Date :Dec 2014

Revision : 1

Page 1/18

## ASSEMBLY MANUAL : HOBIE CAT 14 Std & Race



# HOBIE CAT 14 STD & RACE



Ref :MMHC14SR_GB	Emetteur :MF	Date :Dec 2014	Revision : 1	Page 2/18
<b>ASSEMBLY MANUAL : HOBIE CAT 14 Std &amp; Race</b>				

## TABLE OF CONTENT

Part list .....	3
Ropes and wires .....	4
Rig.....	5
Hull Assembly .....	6
Fitting the trampoline.....	7
Rudder assemblies.....	8
Tiller bar and extension .....	8
Preparation of the mast .....	9
Stepping the mast .....	10
Trapezes .....	11
Mainsail .....	12
Mainsheet system .....	13
Jib kit (Option) .....	14
Advices and maintenance.....	16
Caution & safety tips .....	17



**ASSEMBLY MANUAL : HOBIE CAT 14 Std & Race**

## Part list

Hulls (2)

Front crossbar

Rear crossbar

Mast

Boom

Trampoline

Wire bag

Rig bag

Rope bag

Rudder assemblies (2)

Tiller crossbar

Tiller extension

Main sail & battens (6)



**CAUTION ALUMINIUM MAST  
STAY AWAY FROM OVERHEAD  
ELECTRIC WIRES**





Ref :MMHC14SR_GB	Emetteur :MF	Date :Dec 2014	Revision : 1	Page 4/18
<b>ASSEMBLY MANUAL : HOBIE CAT 14 Std &amp; Race</b>				

## Part list

### Rope bag HC14 Std & Race

1. Trampoline rear line (left).
2. Trampoline middle line.
3. Trampoline rear line (right).
4. Righting line.
5. Main halyard rope.
6. Tack line.
7. Luff tensioning line.



### Wires

- 2 shroud assemblies
- 2 shroud wires
- 1 forestay



### Trapezes

- 2 J&H handles
- 2 adjusting rope locks
- 1 trapeze shock cord
- 2 trapeze lines



**ASSEMBLY MANUAL : HOBIE CAT 14 Std & Race**

## Part list

### Rig bag



Standard



Race

3 stay adjuster

2 aluminium rudder pin

2 Drain plugs + gaskets

5 cotter pins + 9 split rings

4 pylone bolts

1 6 mm shackle

1 Gooseneck

1 Mainsheet system assembled ( Race / STD )

1 Mast step link kit

1 Teflon washer

## ASSEMBLY MANUAL : HOBIE CAT 14 Std & Race

### Hull assembly



1/ Position the hulls in parallel and check the left from the right hull (anti-skid on the deck towards the outside). Position the rear crossbar, Start each corner casting onto the pylon just to get them together. Use the soft mallet.



2/ Fit the side bars onto the castings of the rear crossbar. The flared portion of the sidebar track must be forward and facing inward. Then position the front crossbar on the pylons and fit in it the other ends of the side bars.



3/ Once the frame is assembled and fitted onto the hulls, drive each corner casting down onto the pylon until the bolt holes line up. Strike the casting directly over the pylon only. Use the soft mallet only.



4/ Once the frame is definitely adjusted, we strongly recommend to redrill each bolt passage with an auger of 10 in order to ease the fitting of the bolts (drill alternatively each side of the pylon).

5/ Install the four pylon bolts and nuts, with the nuts inboard. Tighten securely, but do not over-torque.



## ASSEMBLY MANUAL : HOBIE CAT 14 Std & Race

### Fitting of the trampoline



1. Insert trampoline half into the flared sidebar track so that the grommets are running down the center and across the back. Position the forward edge even with the forward crossbar. Insert the forward edge of the trampoline into the front cross bar track adjacent to the corner casting and slide it all the way to the center. Repeat this operation for the opposite side. Install the aft lacing strip by feeding the larger bead into the track in the aft crossbar. Make sure it is centered.

**NB : The hiking straps should be on top.**

2. Tie each aft lacing line to the aft corner casting as follows : Start with an 8 knot at one end of the line which you will block into the inferior hole of the rear casting (behind the crossbar fitting). Then, pass the line through the grommet on the side of the trampoline (from underneath), then in the rear trampoline strip (from above). After 3 or 4 laces, temporarily tie it at the aft end. Repeat the same operation on the other side. **NB : Make sure you passe the line above the crossbar binding nut to avoid friction during sailing.**



3. Tie the center lacing line. Start with a bowline knot. Lace the line back and forth taking up slack as you go. When lacing go through the grommets over/under.

4. Stop the central lacing by a triangle. Use the central grommet on the rear trampoline stripe. Make a key at the end.



5. Temporarily tie off the line at the aft end, then remove slack again by working it out front to back. Lace the two aft lines simultaneously in the same manner.



**NB : As the boat is used, it will be necessary to periodically retighten the lines**

## ASSEMBLY MANUAL : HOBIE CAT 14 Std & Race

### Rudder assemblies



#### RUDDER ASSEMBLY

Identify the **right** rudder assembly (green sticker) and the **left** one (red sticker). They must not be reversed. Slip the rudder pin down through the casting and gudgeons. Insert the split pin in the hole of the rudder pin so that it prevents it from falling down. Do the same thing on the opposite side.

**N.B. : Make sure that the plastic cam has the nose up.**

### Tiller crossbar



The two rudder blades must be parallel or slightly turned inside (3-4 mm). To do this it is necessary to adjust the length of the tiller crossbar. The screw under the tiller crossbar allows for this adjustment. Unscrew it and you can move the bar inside or outside. Once the rudder blades are well trimmed, do not forget to retighten the screw.

Stick aluminium (HC14 STD) – Stick fibre (HC14 Race)



Attach the stick by slipping the pin through the violin screw in the middle of the tiller crossbar.



**ASSEMBLY MANUAL : HOBIE CAT 14 Std & Race**

## Mast preparation

Take the main halyard rope and fix it to the thimble of halyard wire on the mast. Let the wire down on one side of the mast and the halyard rope on the other side of the mast.



Lead the halyard rope temporarily through the black cleat at the mast base, lead it through the shackle that is at the end of the halyard wire and secure it back to the cleat.

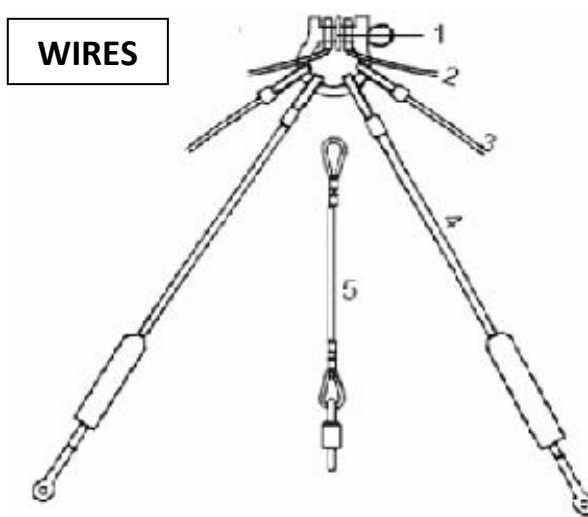
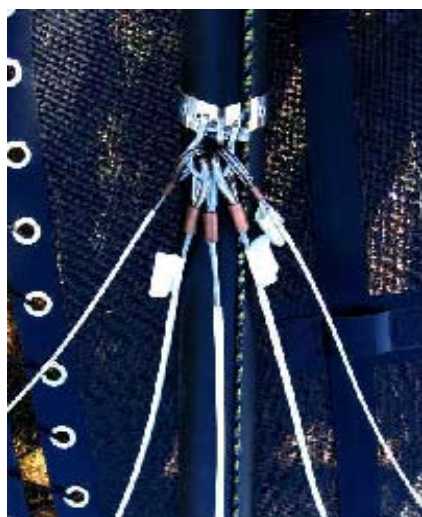

Take the wire set and unroll it along the mast. Use the 8 mm shackle to fix the wires at the mast tang, making sure the wires are arranged on each side of the mast as shown on the drawing:

- 1 : 8 mm shackle
- 2 : trapeze position for Option furler jib
- 3 : Trapeze position without option furler jib
- 4 : Shrouds
- 5 : Standard forestay or pigtail for option furler jib

## ASSEMBLY MANUAL : HOBIE CAT 14 Std & Race

### Stepping the mast



#### ATTENTION - DANGER ALUMINIUM MAST -

When stepping the mast or launching the boat watch for overhead electric wires. Shock or even death could result if the mast comes in contact with overhead electric wires.



Take the bridle wires and attach the opposite ends to the shackle on the bottom of the forestay adjuster. Check that the bolts of the shroud anchor bars are well tightened. Attach the shroud stay adjuster to the anchor bolts on each hull with the clevis pins and lock rings provided.



Place the mast pivot bearing in the mast step cup. Install the mast step link following the instructions supplied with the kit.



lay the mast on top of the frame with the mast head aft. Position the mast foot in front of the step link body in order to insert the pin through. Attach the shrouds to the top holes of the adjusters. Make sure that the shrouds are not crossed at the mast tang. Put the shroud covers over the adjusters. The mast is ready for stepping.

## ASSEMBLY MANUAL : HOBIE CAT 14 Std & Race

### Stepping the mast

#### Shrouds

We recommend that you have someone assist you. As you begin to raise the mast the link will rotate upward. Stand on the rear crossbar and raise the mast to your shoulder. At this point, insure that the shrouds are clear of the rudders and rear corner castings. An assistant is recommended. Walk forward raising the mast as you go. At the full upright position, lean the mast forward against the shrouds and have an assistant attach the forestay (upper hole).



**NB : Later adjustment may be necessary.**

Once the mast is upright, take the pin off the mast step link. Attach one of the shroud to the four or fifth hole of the stay adjuster. Have someone pulling down on the trapeze in order to relieve the shroud. Do the same operation on the opposite side. Caution : it is necessary to have the same tension on both sides. Then put the shrouds covers completely over the stay adjusters.

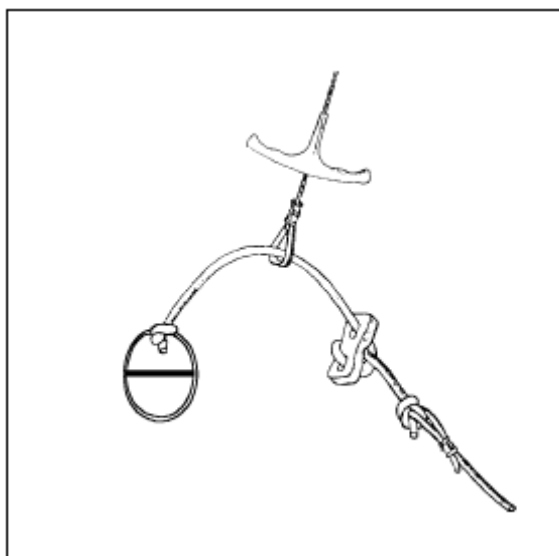

#### Trapeze

Assemble the trapeze adjustment components as shown in the illustration. The shock cord should pass beneath the trampoline frame from the port trapeze line to the starboard line



## ASSEMBLY MANUAL : HOBIE CAT 14 Std & Race

### Main Sail

Unfold the mainsail on the trampoline and insert the battens starting from the top of the sail.

#### How to fix the « Race » batten end caps

Insert the batten tie in one of the hole of the batten end cap, feed it into the opposite grommet of the batten pocket, then into the second hole of the batten end cap, then back in the first grommet and secure it with a knot into the V groove. Batten tension can be varied to suit personal preference or sailing conditions.

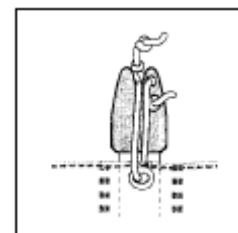

#### How to fix the standard batten end caps



The battens should be stiff. It may be necessary to make adjustments and re-tighten them periodically after sailing

**Before hoisting the sail, place your Hobie Cat directly into the wind**



Take the halyard rope and the halyard wire which are attached together on the mast and pull them apart. Pull on the halyard rope to hoist a bit the halyard wire

Attach the halyard shackle to the head of the sail and secure the shackle pin. Feed the luff into the opening in the mast track and continue pulling the halyard and feeding the sail until it reaches the top. When the sail is all the way up, pull the halyard forward sufficient for the stop sleeve to clear the halyard hook.

## ASSEMBLY MANUAL : HOBIE CAT 14 Std & Race

### Main Sail



Once the sleeve is past the hook position, pull the halyard so that the sleeve will engage the hook when you release tension.

Take the gooseneck and fix it to the groomet of the sail (at the clew). The sheave is facing down. Feed the gooseneck slider in the opening of the mast and pull it down in the gorge.

NB : in order to check that it is secured, untie the halyard rope and pull the sail somewhat down. In order to avoid crossing the halyard rope with the wires, it is recommended to route the halyard from the front to the starboard side and around behind the starboard shroud and trapeze wires. Secure it to the white mast cleat at the bottom of the mast and stow the excess line.



Take the boom. Feed the foot of the sail into the track opening in the forward end of the boom. Fix it to the gooseneck. Tie the luff tensioning line onto the cleat with a palstek (check that the cleat is well fixed) lead it into the gooseneck sheave, down to the cleat and fix it. This allows to tension the luff of the sail.

## ASSEMBLY MANUAL : HOBIE CAT 14 Std & Race

# Mainsheet system

**The mainsheet system is already mounted when delivered with your boat.**

We indicate hereunder the way to thread it, in case that you need to change the line.



Shackle the boom block to the boom block hanger. Shackle the ratchet block to the traveller car (the jam cleat facing inboard).

- Tie a eight figure knot at the end of the mainsheet and feed it through the upper strap of the ratchet block and then,
- up into the first sheave of the boom block from front to rear
- down into the first sheave of the ratchet block from front to rear
- up into the second sheave of the boom block from rear to front
- down into the second sheave of the ratchet block from front to rear
- up into the third sheave of the boom block from rear to front
- down into the third sheave of the ratchet block from rear to front.



Feed it then into the lower strap of the cam cleat of the ratchet block. Run the free end of the mainsheet through the cam cleat of the aft crossbar, through the traveller car from inside to outside, and the dead eye behind the cam cleat. Tie a figure eight knot to secure the line.

Sheet in and out to see if all is well mounted.



## ASSEMBLY MANUAL : HOBIE CAT 14 Std & Race

### Jib Kit (Turbo)

The jib kit is an option available for HC 14 Classic and Race.



If you purchase this kit, you will have first to take the turbo bridles and fix them onto the hull in replacement of the original bridles delivered with the boat.

Then join the bridles to the jib furler using the 6 mm shackle that is at the bottom of the furler. NB : before stepping the mast, roll up the line into the furler.



Take the anchor bars and fix them on the side bars.

Fix the transversal wire under the trampoline between the two side bars. Use the stay adjuster to tense the wire.



To mount the blocks on the trampoline two persons are necessary. Take off the shackles of the blocks, go under the trampoline, insert the shackles around the wire and lead it through the eyelet of the trampoline. Then attach the block on the shackle using the cotter pin and the split ring delivered with the shackle.

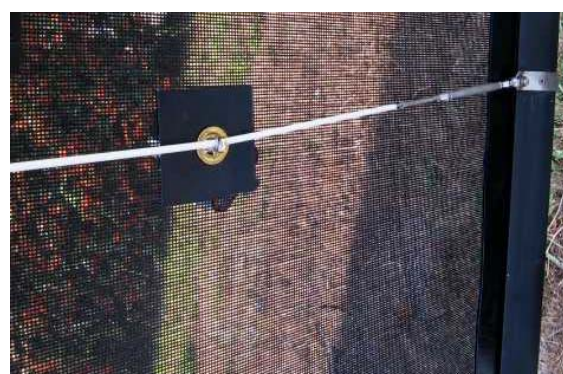

Before hoisting the jib, when you install all the wires on the mast, you will have to replace the forestay by the pigtail with swivel.

**IMPORTANT :** The jib replaces the forestay. Don't forget to fix it to the swivel before stepping the mast. To use the furler, you will have to fix a plastic cleat (supplied with two screws) on the front crossbar, slightly inclined, at 180 mm from the dolphin striker





## ASSEMBLY MANUAL : HOBIE CAT 14 Std & Race

support.

### Kit de foc (Turbo) - end

When the boat is masted, fix the tack point of the jib at the first hole of the stay adjuster of the jib furler. Then readjust the tension of the shrouds.



Take the jib clew blocks with the large shackle, and fix them to the jib clew point. Take the jib sheet line and install it as follows : start on the top of the right block with a knot on the fixed point of the block, lead it up through one of the two jib pulleys, then down to the block on the trampoline. The do the other side of the jib in a reverse

Take the furler line, lead it through the jib plastic cleat fixed on the front crossbar and attach it around the toe strap to avoid it from falling in the water during sailing.

## ASSEMBLY MANUAL : HOBIE CAT 14 Std & Race

### Advices and maintenance



#### Before sailing check the following points :

1/ Install the drain plugs – do not overtighten, hand tight is sufficient. Overtightening may cause the drain plug flange to distort and cause leakage.

2/ Tension the rig. This can be accomplished by having your assistant hang from the trapeze or you can use mainsheet tension on one side at a time so that you can adjust the shroud position in the side stay adjusters.



3/ Check all fastenings :

- Mast tang shackles and shrouds (to prevent the mast to fall down)
- pins and trapeze rope locks (to prevent falling out in the water if the trapeze is not well fastened)
- pins and spring rings on the forestay and shrouds (to prevent the mast to fall down)
- spring rings on the rudder pins (to prevent loosing the rudder assembly in case of capsizing)



#### Transport and launching

In order to avoid hull damages :

- Always use a dolley to transport your Hobie on the beach (even if it is sand beach) and for launching. Step into the water with the dolley and once the cata is afloat take out the dolley.
- DO NOT BEACH. Beaching, even smoothly, may damage the hulls. use your beach dolley to take the boat out of the water.
- For towing, always use an homologated road trailer.



#### Maintenance & repairs

- Always wash the hulls and the sails with fresh water after sailing in salt water.
- Take off the plugs to drain the water from the hulls.
- In order to avoid expensive repairs, it is recommended to check wear of hull bottoms as follows : as soon as the first woven glass cloth appears, you should apply gelcoat or resin to protect the fiberglass. If the wear is already so advanced that several layers of glass fiber have been worn through or the colored wear indicator is showing, stop using them and rebuild the bottom with fiberglass and resin.

CAREFULLY READ AND OBSERVE THE SAFETY ADVICES MENTIONED IN THE FOLLOWING PAGE.





**ASSEMBLY MANUAL : HOBIE CAT 14 Std & Race**

## CAUTION / SAFETY TIPS

### Read carefully before sailing

- Make sure someone on land is informed about where and how long you intend to sail your boat.



- Whether on land or on the water, **watch for overhead power lines**. Contact with power lines can cause serious injury or death.

- **DO NOT sail** while under the influence of **alcohol and/or drugs**

- Only sail in conditions in which you feel comfortable and where you feel confident that you can safely sail the boat. **Never go out in conditions beyond your ability.**



- Everyone on board should **wear a life jacket** at all times.
- If you are in the water, remain in contact with the boat, even if it is capsized. A sailboat can drift away faster than a person can swim.
- Never sail without a righting line.
- **Wear appropriate clothes**. Wear a wet suit or dry suit in cold weather or cold water conditions.
- Remain seated while sailing.
- Learn the right of way rules and when in doubt, give way to others.
- When not sailing, always keep the boat pointed into the wind whether in the water or on the beach.

- **Read the instruction manual carefully.**

- Make sure everyone on the boat reads and understands these safety instructions.



- **ALWAYS check that the drain plugs** are screwed in before launching your boat on the water.